



manifeste™

CRÉE DES PRODUITS ESSENTIELS ET INTÉMPORELS

*Les pages suivantes décrivent les valeurs que l'objet/solution
devra porter. Cette description est faite avec des mots,
soutenus par les visuels de 9 produits-icônes qui ont marqué
l'histoire du design*

personnel

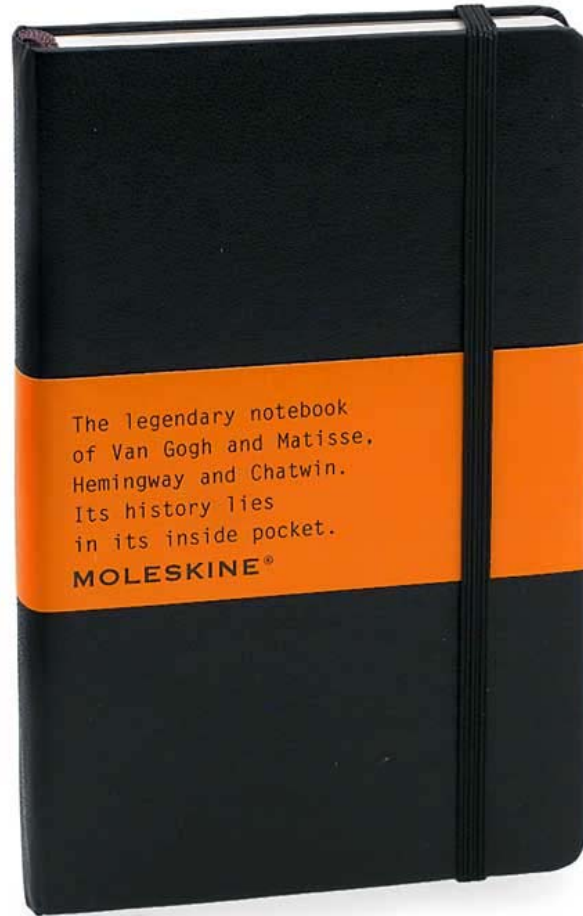

procure du plaisir



permet l'expression de soi



luxueux



utile

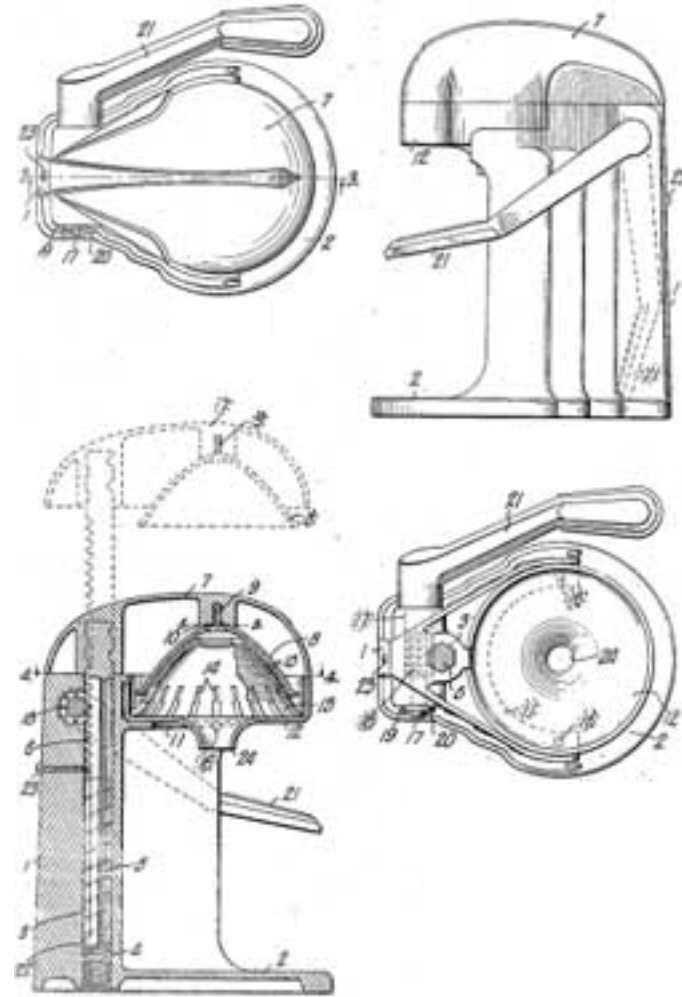

sensuel



pratique



moderne



portable



lancement du produit/solution dans le cadre d'un évènement fort